



ICE STORAGE BIN

B-301SA

PARTS LIST

[CHINA, HLP, HKR]

G006, G006-C101, G006-C102, G006-C104



PLATON SERVICE

8 (800) 500-34-47

www.platonservice.com

U-1 JUL. 2009

G006-3234 (1122)

List of Specifications

MODEL	MODEL NUMBER	DESTINATION
B-301SA	G006	CHINA
B-301SA	G006-C101	HLP
B-301SA	G006-C102	CHINA
B-301SA	G006-C104	HKR



PLATON SERVICE

8 (800) 500-34-47

www.platonservice.com

AUXILIARY CODE

U - 1

The auxiliary code is the first two characters in the serial number. The first character indicates the production year. Years progress or regress in alphabetical order. The series of letters and skipped letters depend on UL listing, production, and model. See the auxiliary code(s) and corresponding year(s) on the front cover.

The second character indicates significant part changes within the same year. Base is "1" and this number advances for each change. If there is no significant part change at the turn of the year, this number starts from "0."

FASTENER PART NUMBER

SCREWS

F S T 0 3 0 6 F 0

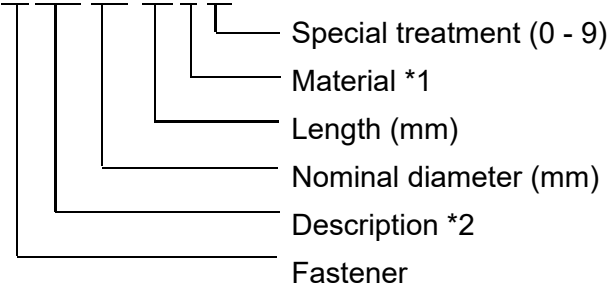

*1

- F: Steel
- S: Austenitic stainless steel
- M: Martensitic stainless steel
- B: Copper alloy
- P: Polycarbonate
- N: Polyamide
- V: PVC
- A: ABS
- X: Polyacetal
- L: Aluminum

NUTS & WASHERS

F W S P 0 5 S 0

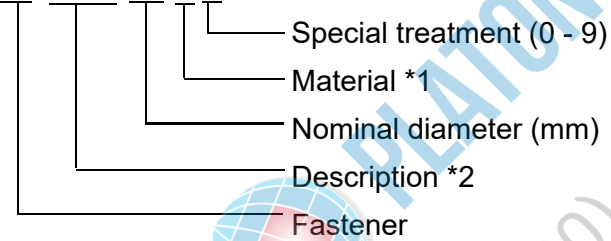

*2

- First letter
- S: Machine screw
- T: Tapping screw
- M: Wood screw
- B: Bolt
- W: Washer
- N: Nut

PLATON SERVICE
8 (800) 509-4444
www.platonservice.com

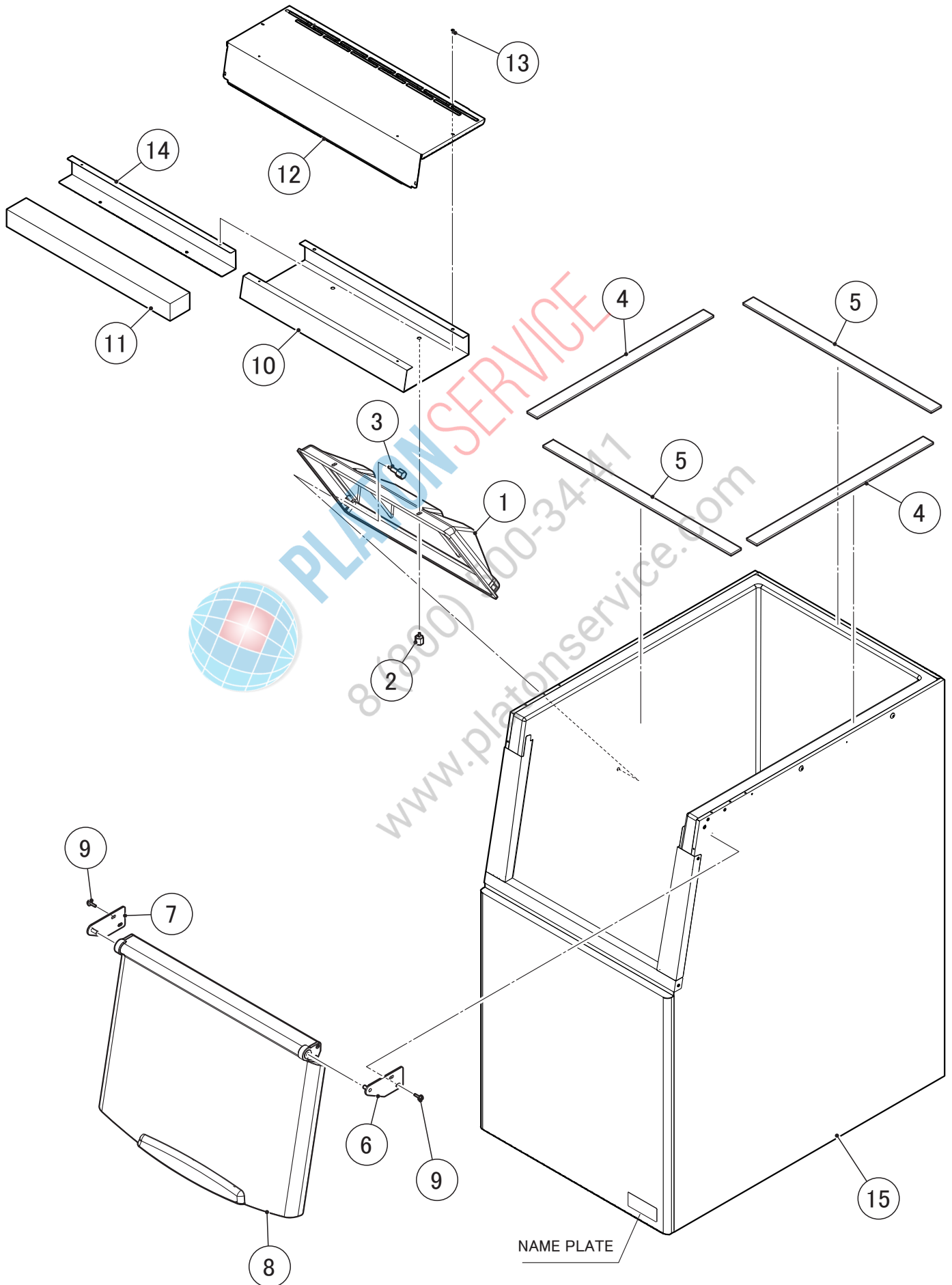

MODEL: **B-301SA**

TITLE: **A. BIN ASSEMBLY**

INDEX NO.	DESCRIPTION	MATERIAL OR MODEL NUMBER	PART NUMBER	REQ'D NUMBER			
				U-1 and later			
B	ACCESSORIES	except G006-C101	A01904-01	1			
		HLP G006-C101	A01904003	1			
1	BAFFLE - 3		119680P01	1			
2	THUMBSCREW		415949G11	2			
3	THUMBSCREW		434168G01	2			
4	GASKET		474046P01	2			
5	GASKET		474046P03	2			
6	HINGE (R)		474049G01	1			
7	HINGE (L)		474048G01	1			
8	DOOR - 3		257307G01	1			
9	FLANGE BOLT		P02005-01	4			
10	FRONT FRAME COVER-3		372926P01	1			
11	INSULATION(C)		372942P01	3			
12	TOP COVER - 3		277877M01	1			
13	RIVET		7170-0002	8			
14	FRONT FRAME - 3		389457M01	1			
15	BIN BODY-3		119679G02	1			

PLATON SERVICE

8 (800) 500-3444

www.platonservice.com

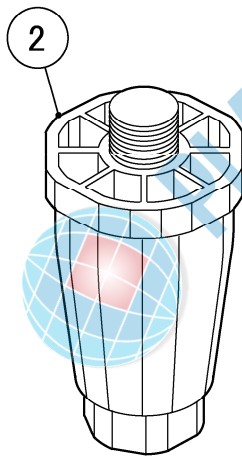
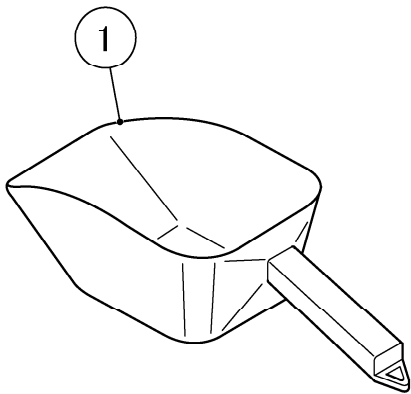

(CHINA:H90)

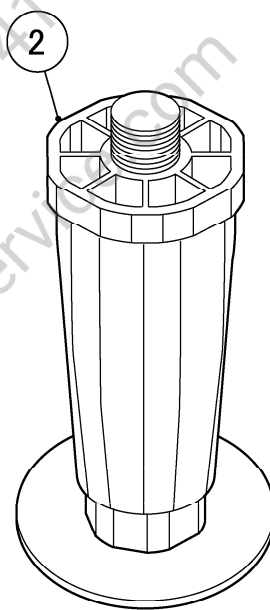

(HLP:H150)

PLATON SERVICE
8 (800) 500-34-47
www.platonservice.com

MODEL: **B-301SA**

TITLE: **B. ACCESSORIES**

INDEX NO.	DESCRIPTION	MATERIAL OR MODEL NUMBER	PART NUMBER	REQ'D NUMBER			
				U-1 and later			
1	SCOOP		208185-01	1			
2	LEG	except G006-C101	P04879-01	4			
		HLP G006-C101	P05014-01	4			



PLATON SERVICE
 8 (800) 500-34-47
www.platonservice.com